

Prices valid from August 2022

PRICE LIST 2022

NATURAL GENIUS

Listone
Giordano®



Listone Giordano®

**SIGN YOUR WOOD FLOOR
WITH LISTONE GIORDANO ALUMINIUM PLATE**

(check accessory section)

All the prices in this document are vat excluded

2 **ENVIRONMENTAL PROTECTION**

3 **CERTIFICATIONS**

4 **GENERAL INFORMATION**

ΠΣΤΥΡΑΚΑ ΓΕΝΙΚΩΣ

6 Technical information

8 Medoc (design Michele De Lucchi)

12 Slide (design Daniele Lago)

18 Foxtrot (design Matteo Nunziati)

22 Biscuit 1 (design Patricia Urquiola)

26 Biscuit 2 (design Patricia Urquiola)

30 Biscuit 3 (design Patricia Urquiola)

34 Biscuit 5 Small (design Patricia Urquiola)

38 Biscuit 5 Large (design Patricia Urquiola)

42 Fabrique (design Marc Sadler)

46 Perigal (in cooperation with Paola Lenti)

52 Between (design Alexander Brenner)

56 Conte (design Alexander Brenner)

60 Loop (design Sebastiano Canzano)

64 Factum (design Dante Oscar Benini e Luca Gonzo)

68 Accessories

72 **CLEANING AND MAINTENANCE PRODUCTS**

ENVIRONMENTAL PROTECTION: BIOSPHERA



Biosphera is a marking system based on Listone Giordano's green procurement policy which meets the need to provide consumers with synthetic, clear and transparent information on the origin of the raw materials used. It focuses solely on the issue of forestry resources protection, in particular on their use in multilayer wooden floors. As such it is not meant to replace the internationally established certification protocols, which generally have broader fields of

application and wider scope. Listone Giordano through Biosphera aims to spread among its customers a culture of environmental responsibility and promote the purchase of certified wood.

BIOSPHERA CERTIFIED

The mark identifies products made with raw materials with certified forestry management according to internationally recognised standards (FSC, PEFC, SFI, OLB, LEI, etc.)

BIOSPHERA CONTROLLED

The mark identifies products made with raw materials whose legal origin and forestry management, although not yet certified, is however validated by specific audits and documentary evidence. This is usually the intermediate step towards the official forestry certification.

HEALTH PROTECTION: CRYSTALCARE

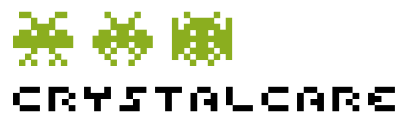

How would you enjoy walking barefoot on your wood floor?
Thanks to Crystalcare, the antibacterial finish developed by Listone Giordano and ICRO, it is now totally safe. A simple additive incorporated into Xplus2, Naturplus2, Mattplus, Invisibile Touch and Oleonature finishes ensures the antibacterial certification issued by CATAS S.p.A. laboratories according to ISO

standard 22196:2007. Your well-being, your children's health and the safety of the places where they live and play in are the main focus of Crystalcare's extraordinary innovation.

Also developed for wood floors installed in healthcare and medical applications.



CERTIFICATIONS



The mark of responsible forestry

"Ask for FSC certified products ®"

FSC®

Certification of the chain of custody ensures the raw material originate from forests managed according to strict environmental, social and economic standards.



PEFC

The certification of the chain of custody stating the provenance of the products sourced from sustainable forests.

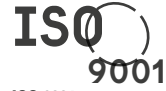

ISO 9001

Certification of the Company's quality management system.



ISO 14001

Certification of the environmental management system.

SISTEMA DI GESTIONE SICUREZZA CERTIFICATO



UNI ISO 45001:2018

ISO 45001

Certification of Occupational Health and Safety Management System.



F-4 STARS

F-4 STARS

Listone Giordano wood floors comply to the most restrictive class F**** classification system on formaldehyde emissions defined by the Japanese Ministry of Land, Infrastructure, Transport and Tourism (MLIT).



Formaldehyde

Listone Giordano fully complies to the class E1 limits, which is amongst the strictest European regulations currently in force (UNI EN 14342).

US TSCA

Certification CARB2 / TSCA Title VI

The plywood panels used for Listone Giordano wood floors are in compliance with US TSCA Title VI and CARB phase 2 Formaldehyde emissions.



TÜV Proficert-Product Interior

It certifies that Listone Giordano® 2-layer wood floors are complaint with the most stringent health and quality criteria selected by TÜV HESSEN (PREMIUM level). It's a voluntary certification specifically developed for construction products for interiors.



French Certification

Emissions of Volatile Organic Compounds

All Listone Giordano products tested according to n°2011-321 French Decree have attained A+ rating, the highest among those in the Decree.



Toy certification

Listone Giordano finishes are approved according to standard EN71-3 which assures fitness for use in children's toys.



Fire-proof reaction

The updated products list related to classes of fire-reaction is available on www.listonegiordano.com



CE certification

Listone Giordano strictly complies to all CE rules related to wood floors.

GENERAL INFORMATION.

WOOD, A LIVING MATERIAL

Wood is a "living" material interacting with the environment and affected by external factors such as sunlight, temperature, air moisture and daily use.

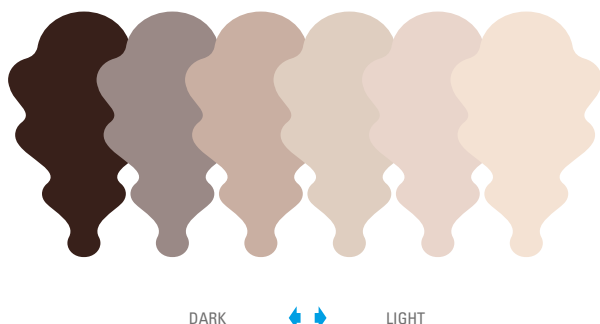

COLOUR

The colour of wood largely depends on certain substances it contains, known as extractives. The colour of these substances is modified by exposure to air and light, so that the original colour of every parquet floor undergoes more or less marked transformations over time.

Due to the high extractives content in tropical wood species, such as Iroko and Doussié, they are especially prone to chromatic changes usually evolving into darker brown hues, sometime creating different colour tones.

Teak may initially show very conspicuous colour variations. These variations tend to diminish and disappear over time and the colour turns a consistent medium-light hue. Oak features a fair colour stability. With exposure to light, it evolves into warmer hues, with the yellow component becoming more predominant. This phenomenon occurs even in pigment finished products (i.e. Michelangelo and Grisaglie range).

Monteriggioni and Montesiepi initially show marked colour variations (contrasts). Over time, their appearance will tend to homogenize towards a more neutral and lighter gray tone. This evolution happens even without light and air exposure and it's due to the natural colour change of the surface treatment.

Long exposure of some wood species, including the products of Michelangelo and Grisaglie ranges, to intense and direct sunlight, for instance near a French window, may cause discolouration (UV rays produce these effects on many materials other than wood). In order to limit this phenomenon, we recommend the use of curtains or special UV filtering films to be applied to the glazing.

SILVER GRAIN

Oak boards sourced from a perfectly radial section of the log feature straight grain as well as ray flecks, typical lustrous figures even called silver grain.

Silver grain has always been sought after as an indicator of quality and value. In addition to the aesthetic factor due to more even grain, it also indicates better technical performance (dimensional stability, impermeability, etc.).

SAMPLES

Wood is a natural material, uneven and variegated by its very nature: every item is unique and unrepeatable.

Therefore **samples consisting of few boards can only provide a general idea of what a parquet will look like and cannot fully show the different hues, grains and unique features of each element.** The images don't have any contractual value; they provide only an indication of specific elements of wood selection, like wood patterns, knots, silver grain, and other varied grains of a material shaped by nature.

The colour shade visualized has to be considered indicative, as it could differ sensibly from the actual one due to the device screen settings used to visualize the image.

As mentioned above, wood colour tends to change over time, due to exposure to light and air. That is why a recently installed wood floor typically features a different appearance and hue compared to a sample panel of the same product, which has been exposed to natural light for some time.

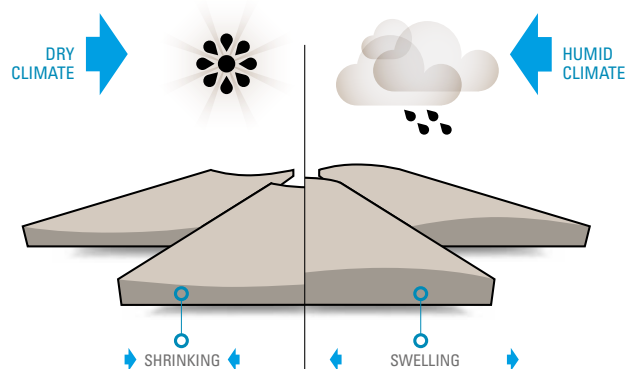

MATERIAL STORAGE

Store the boxes of hardwood flooring in safe places indoor and dry places, always with temperature between +15°C (59°F) and +30°C (86°F), never in places with a direct effect of the sunlight (for instance open containers or warehouses with metal roof).

In very cold countries (for example extreme northern or southern part of the world), it is necessary to stock parquet in a heated storage, at least to 15°C (59°F); in very warm countries (for example countries in the equatorial area of close to it) it is necessary to stock parquet in refrigerated storage, not more than 30°C (86°F). **These directions are valid also for the transportation.**

GLUE

Ecolfit® Listone Giordano® is the single component, isocyanate and solvent free, silitated polymer-based adhesive with a very low emission of volatile organic compound recommended for all the range of our hardwood floors.

Do not use two-component adhesives as they can damage significantly and irreversibly the appearance of all the finishes, particularly those oil based. It's forbidden the use of Pulplus® Listone Giordano® or aggressive solvents to remove adhesive residues on oil based finished hardwood floor especially if stained.

CLIMATIC CONDITIONS

Wood naturally undergoes swelling or shrinking, depending upon the moisture and temperature conditions it is exposed to.

For a floor to always be in perfect conditions, maintain the humidity level of the atmosphere between 40% and 65%. The air temperature has never be lower than 15°C in the coldest season and has never exceed 30°C in the hottest one:

this is also the same environmental conditions recommended for ensuring people's comfort and health.

These climatic conditions should be maintained during installation as well as afterwards, including when the premises are not in use. **In certain situations, especially during the winter months, it may be necessary to use air humidifying systems in order to assure compliance with the indicated conditions.**

In case of underfloor heating, in addition to the requirements for temperature and air humidity, the floor surface temperature limit of 27°C with system in operation should never be exceeded. To prevent exceeding this limit, we recommend not to cover the floor with thick rugs or other materials having high thermal resistance in the case of underfloor heating.

In case of cooling system condensation has never appear in every part, either of the system and of the subfloor.

Listone Giordano® products featuring plywood support (identified in the "Technical specifications" section) may also be used in particularly severe conditions of temperature and humidity, i.e. with relative air humidity down to 30%, and with floor surface temperature up to 29°C.

Under these conditions, the product retains its integrity and functionality, however it may be subject to phenomena typically connected to wood shrinking, such as warped board section (cupping), the formation of gaps between the boards, or even the formation of cracks within the individual board.

Anyway, the appearance overtime of a few tiny cracks on the top hardwood layer is a natural phenomenon and inevitable in statistic terms even if the recommended climatic conditions are complied with.

HARDNESS

The individual hardness features of all wood species processed to manufacture the parquet products herein make them suitable for hardwood flooring.

However surface dents or marks may occur in even the hardest of woods, if the hardwood floor undergoes impacts, is hit by falling objects, or is loaded with highly concentrated weight (stiletto heels, ladders, etc.).

HANDCRAFTED PROCESSING

Atelier and Natural Genius wood flooring collections feature uneven shape and appearance typical of a hand-made product. Visible differences between planks or within the same plank (i.e. uneven and/or rough surface, difference in hues) are not defects but rather represent the very essence of the products.

Some processes cause roughness and minor splintering on the surface, which the cloths used for cleaning may get caught in. The presence of said roughness and tiny splintering must be carefully assessed if the flooring is for barefoot use.

FINISHES

The wear due to treading tends to alter the gloss and the resistance of the finish over time, especially in high-traffic areas.

Correct maintenance can keep this unavoidable phenomenon under control.

A gloss alteration may be caused also by energetic and repeated rubbing, due for example to the attempt of removing a stain.

Products with natural oil finishes tend to yellow slightly, should these products be kept in their boxes for a long time or not be exposed to light and air. This is an utterly natural and transitory phenomenon.

All it takes for the product to regain its original appearance is to expose the boards to air and direct sunlight for a short time.

In the event of exposure to indirect lighting, typical of indoors premises, the process may require a longer time.

Natural oil-based finishes have the characteristic of continuing to permeate the wood fibres even after application, while the material is still in its packaging. Upon installation, the surface of the product may therefore appear especially "dry" in some areas. In that case all it takes is to apply the appropriate maintenance product immediately after installation.

Wood is a natural material, therefore colour tone and absorption of the finish may vary from one board to the other, or even in the same board according to the variation of its fibre. This colour tone variation is visible even after the application of colour pigments proving the authenticity and the uniqueness of each board.

CLEANING, USE AND MAINTENANCE INSTRUCTIONS

Instructions about cleaning, use and maintenance of the wood flooring are available in the dedicated page of the website www.listonegiordano.com/international featuring the technical sheets. **We recommend checking it when selecting the product.**

TECHNICAL INFORMATION

FINISHES

NATURPLUS2 MATT

CRYSTALCARE

Solvent-free varnish coating, which emphasizes the wood's grain and authenticity and highlights the natural matt feature. The finish features the anti-bacterial Crystalcare technology.

INVISIBLE TOUCH

CRYSTALCARE

Water-based finishing that protects the wood whilst keeping the natural appearance and colour of an untreated surface. This finishing features the anti-bacterial Crystalcare technology.

OLEONATURE

CRYSTALCARE

Natural oils-based finishing air-dried. Thanks to a special protective treatment applied as a last coating, it is characterized by high protection and practicality of maintenance. This finishing features the anti-bacterial Crystalcare technology.

SURFACE

Filo di Lama

Rough sawn surface effect.

Filigrana

The brushing treatment of the surface enhances the wood grain pattern.

GRADES

Rigata

Straight grain, substantially homogenous colour. Presence of small knots, sometime open and typical characteristics of the wood species.

Elegant (Fibramix)

Mixed grain. The boards may feature colour variations and knots. In the extra wide boards (width from 140 mm and over), knots may even be filled or partially filled.

Esprit

Mixed grain, naturally uneven hue variation, marked and widespread presence of filled or open fissures, as well as encased, tight or only partially filled knots.

The hardwood flooring planks of the Natural Genius collection have the typical features of handmade products.

Visible differences between planks or within the same plank (i.e. uneven or rough surface, difference in color tones) are not defects but rather represent the essence of these products.

Wood is a natural and variegated material. Pictures and brief descriptions featured in this pictorial are not able to fully represent the appearance of each product and must therefore be considered as indicative and not contractual (non binding).

A more complete and detailed description of the different grades is available on the website www.listonegiordano.com.



ნატურალ გენიუს



SKYARTE PRESENTS
NATURAL GENIUS

Listone Giordano ONE crossmedia platform goes in depth and covers the best in Architecture, Design, Nature and Culture.

ONE.LISTONEGIORDANO.COM

medoc

| Design: Michele De Lucchi con Philippe Nigro

The particular tapered geometry of the boards is the epitome of ancient values creating a weaving wooden texture with a contemporary twist.

A wood floor conceived by Michele De Lucchi boasting prestigious international design awards.





TOP LAYER THICKNESS: 3,5 mm
 SUPPORT THICKNESS: 9 mm
 TOTAL THICKNESS: 12,5 mm
 SUPPORT: BIRCH MULTILAYER
 WEIGHT: 9 kg/m²
 THERMAL RESISTANCE: 0,077 m²K / W
 INSTALLATION: GLUED-DOWN

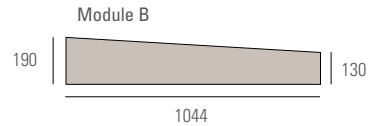
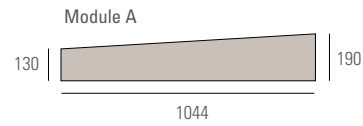
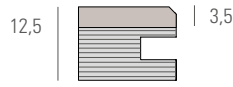

INSTALLATION PATTERNS

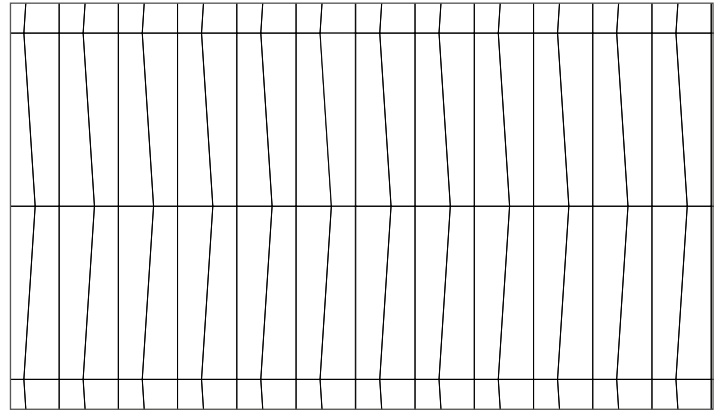
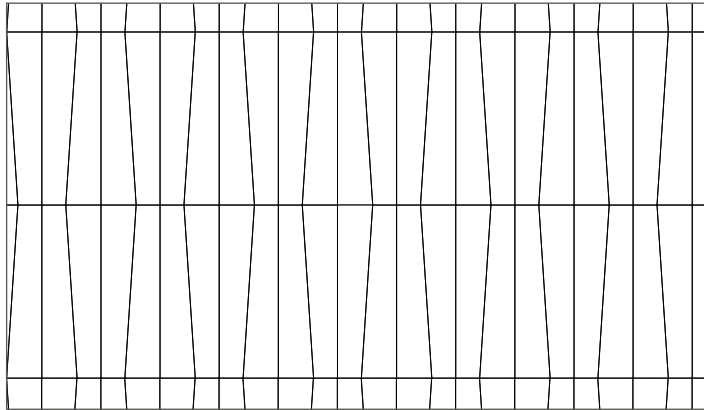

These elements are milled with groove profile. They interlock by means of split tongues supplied with the material.

In order to lay this specific geometric pattern, boards of the same shape will be supplied half A and half B.

See technical sheet for more information on the installation patterns.

These products are compatible with

heating and cooling underfloor systems provided they are installed with the glue down method and the instructions on operating temperature and humidity are strictly complied with.

Product's features may change with respect to the information in this document. For update information please check the technical sheets available on www.listonegiordano.com.

We recommend to read the "General information" on page 4 and 5 during the selection and purchasing phase focusing on the installation, use and maintenance instructions available on www.listonegiordano.com.

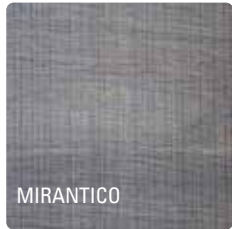

TOP LAYER	FEATURE	SURFACE	FINISH	GRADE	130-190 total thickness 12,5 mm top layer thickness 3,5 mm length 1044 mm
OAK	Pienza 1405	filo di lama	Oleonature	Esprit	346,25
	San Gimignano 1311	filo di lama	Oleonature	Esprit	346,25
	Montalcino 1118	filo di lama	Oleonature	Esprit	346,25
	Bagno Vignoni 1262	filo di lama	Oleonature	Esprit	346,25
	Erice 1312	filo di lama	Oleonature	Esprit	365,40

Price are in €/m²

TERRE DI VIGNA by
PASSONI DESIGN®

The wood floor is tinged with a special color obtained by distillation from wine in collaboration with Passoni Design. The selected grape pomace combined with natural pigments endow Medoc with a unique color depth. A patented, cutting-edge and fully natural color technology is the result of the passionate research carried out by the Passoni laboratories.

130-190
total thickness 12,5 mm
top layer thickness 3,5 mm
length 1044 mm

OAK	Mirantico	filo di lama	Oleonature	Esprit	346,25
-----	-----------	--------------	------------	--------	--------

Price are in €/m²

Cut-sawn effect of the surface

Roughness of the surface and small splintering may trap the cleaning cloths. Please be aware of this roughness and splintering when walking barefeet on the floor.

may exceed the one originally ordered with 4 m² or 4% tolerance (the highest between the two).

Before placing the order please always check availability and delivery time with the sales assistants.

Minimum quantity is 25 m². Smaller quantities are to be evaluated upon request. If accepted 300 € will be charged as setup **fixed costs**.

The delivered and invoiced quantity





Design: Daniele Lago

Modular floor covering made of trapezoidal geometrical shapes. Simple sliding movements along the trapezoid's bases or according to the oblique sides' thread combined with free rotation create countless patterns. The planning of

specific geometric relations in defining the shapes results in original and unique configurations that recall the mathematical laws underlying crystals' generation in nature.





TOP LAYER THICKNESS: 1 mm
 SUPPORT THICKNESS: 12 mm
 TOTAL THICKNESS: 13 mm
 SUPPORT: MULTILAYER COUNTER-BALANCED
 WEIGHT: 9 kg/m
 THERMAL RESISTANCE: 0,083 m² K / W
 INSTALLATION: GLUED-DOWN

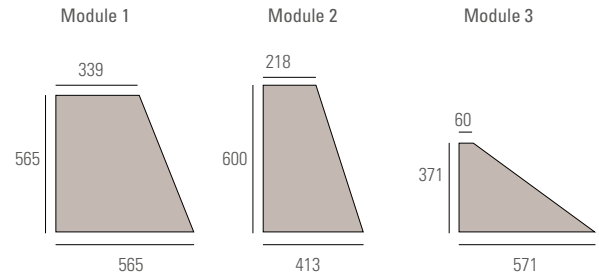
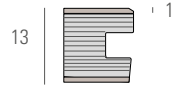

TOP LAYER THICKNESS: 3,5 mm
 SUPPORT THICKNESS: 9 mm
 TOTAL THICKNESS: 12,5 mm
 SUPPORT: BIRCH MULTILAYER
 WEIGHT: 9 kg/m²
 THERMAL RESISTANCE: 0,077 m² K / W
 INSTALLATION: GLUED-DOWN

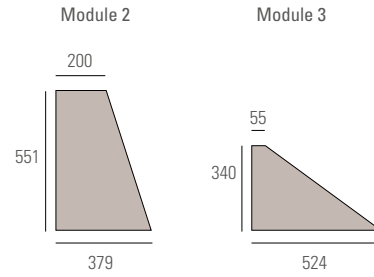
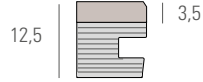

INSTALLATION PATTERNS

ELIO

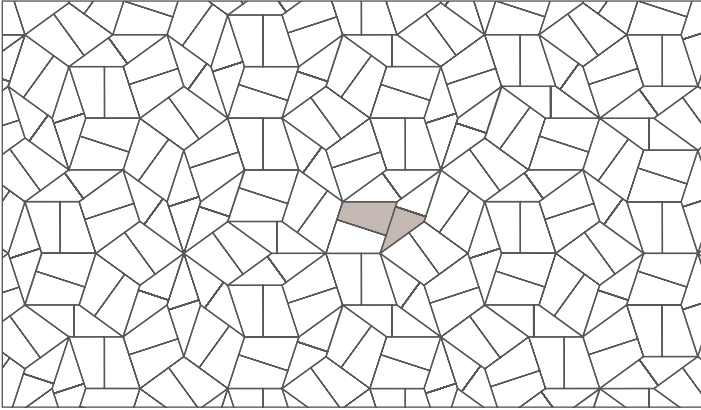

IDROGENO

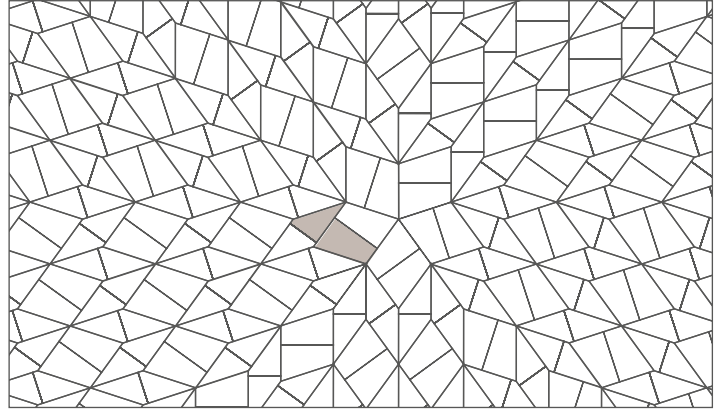

LITIO

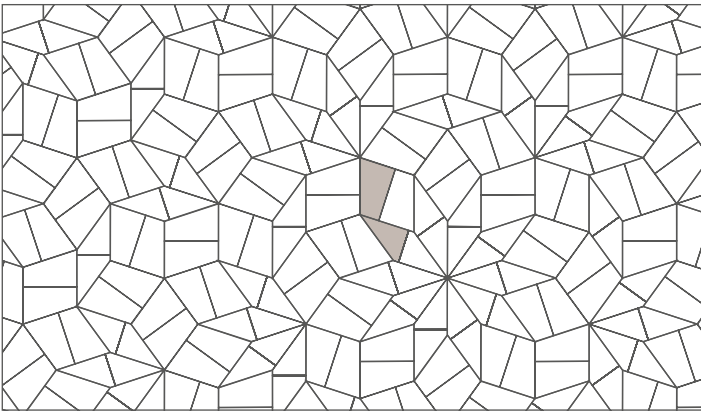

SODIO

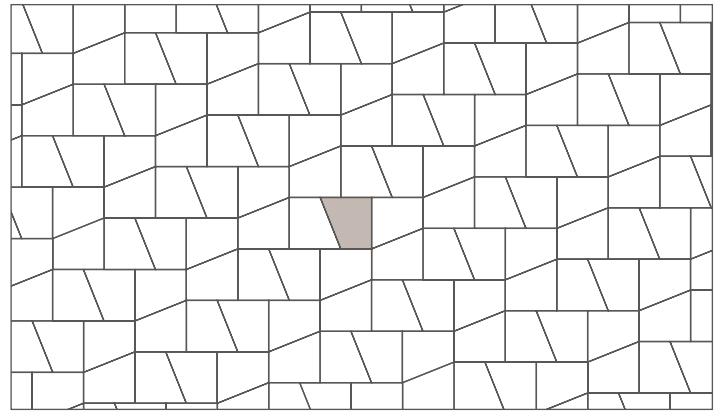

These elements are milled with groove profiles on four sides. They interlock by means of split tongues supplied with the material.

Please check the technical sheets for more information on the installation patterns.

These products are compatible with heating and cooling underfloor

systems provided they are installed with the glue down method and the instructions on operating temperature and humidity are strictly complied with.

Product's features may change with respect to the information in this document. For update information please check the technical sheets

available on www.listonegiordano.com

We recommend to read the "General information" on page 4 and 5 during the selection and purchasing phase focusing on the installation, use and maintenance instructions available on www.listonegiordano.com.



TOP LAYER	FEATURE	FINISH	GRADE	total thickness 13 mm top layer thickness 1 mm
OAK	Michelangelo ⁽¹⁾	Naturplus2 Matt	Rigata	322,15
	Grisaglie ⁽²⁾	Naturplus2 Matt	Rigata	322,15

 Price are in €/m²

TOP LAYER	FEATURE	SURFACE	FINISH	GRADE	total thickness 12,5 mm top layer thickness 3,5 mm
OAK	Michelangelo ⁽¹⁾		Naturplus2 Matt ⁽³⁾	Elegant (Fibramix)	328,55
	Michelangelo ⁽¹⁾		Oleonature	Elegant (Fibramix)	335,50
	Grisaglie ⁽²⁾		Naturplus2 Matt	Elegant (Fibramix)	328,55

 Price are in €/m²

Waste due to elements' perimetric cutting is calculated between 10% and 20% though percentage may slightly vary according to dimension and shape of the surface area to be laid.

Our technical department is available, on the basis of CAD drawings provided by the client, to elaborate the floor plan drawings and detailed list of the number of modules required for flooring installation.

Minimum quantity is 25 m². Smaller quantities are to be evaluated upon request. If accepted 300 € will be charged as setup **fixed costs**.

The delivered and invoiced quantity may exceed the one originally ordered with 4 m² or 4% tolerance (the highest between the two).

Before placing the order please check always availability and delivery time with the sales assistants.

⁽¹⁾ Available in Cannella, Biancospino, Montblanc and Tortora colours.

⁽²⁾ Available in Grigio di Luna.

⁽³⁾ The **Naturplus2** finish can be ordered at no extra charge until 30/09/22. From this date on, it will be available as a customization: please ask the sales assistants for a quotation.



foxtrot

Design: Matteo Nunziati

Modular floor covering made of three geometrical shapes: one square and two rectangles which keep the balance between lines and surfaces, between

materials and colours inspired by a sign of modernity.





TOP LAYER THICKNESS: 1 mm
 SUPPORT THICKNESS: 12 mm
 TOTAL THICKNESS: 13 mm
 SUPPORT: MULTILAYER COUNTER-BALANCED
 WEIGHT: 9 kg/m²
 THERMAL RESISTANCE: 0,083 m² K / W
 INSTALLATION: GLUED-DOWN

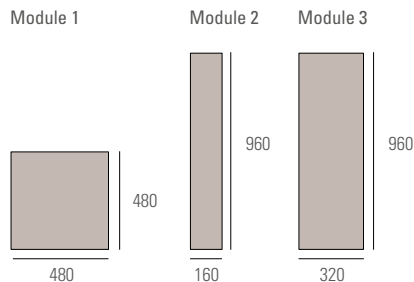
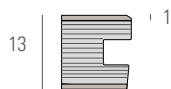

TOP LAYER THICKNESS: 3,5 mm
 SUPPORT THICKNESS: 9 mm
 TOTAL THICKNESS: 12,5 mm
 SUPPORT: BIRCH MULTILAYER
 WEIGHT: 9 kg/m²
 THERMAL RESISTANCE: 0,077 m² K / W
 INSTALLATION: GLUED-DOWN

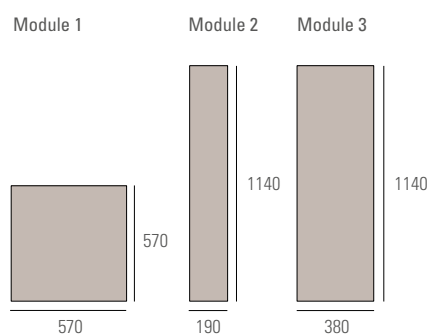
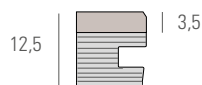

INSTALLATION PATTERN

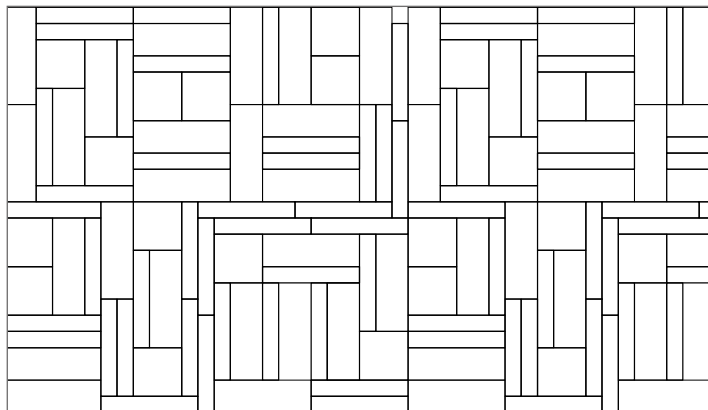

The version in 1 mm top layer thickness is milled with groove profiles on all four sides. The version in 3.5 mm top layer thickness is milled with split tongue and groove profile on the two longitudinal sides, with groove profile on the two transversal sides. The interlock is made by means of split tongues incorporated in the supply.

Each pack unit contains 2 elements of "Module 1", 6 elements of "Module 2" and 4 elements of "Module 3".

Please check the technical sheets for more information on the installation patterns.

These products are compatible with heating and cooling underfloor systems provided they are installed with the glue down method and the instructions on operating temperature and humidity are strictly complied with.

Product's features may change with respect to the information in this document. For update information please

check the technical sheets available on www.listonegiordano.com.

We recommend to read the "General information" on page 4 and 5 during the selection and purchasing phase focusing on the installation, use and maintenance instructions available on www.listonegiordano.com.

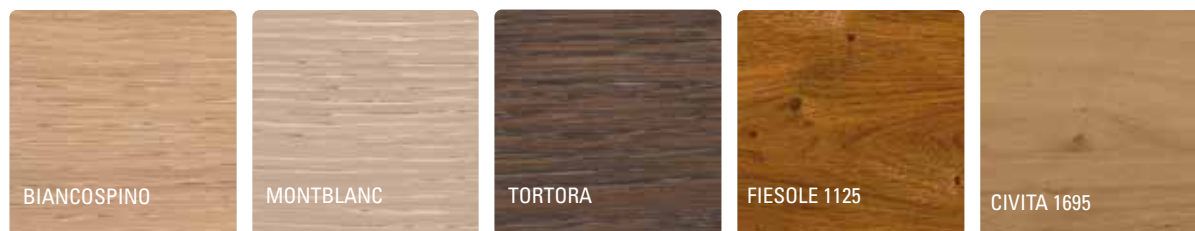

TOP LAYER	FEATURE	FINISH	GRADE	Module 1 total thickness 13 mm top layer thickness 1 mm dimensions 480x480 mm	Module 2 total thickness 13 mm top layer thickness 1 mm dimensions 160x960 mm	Module 3 total thickness 13 mm top layer thickness 1 mm dimensions 320x960 mm
OAK	Michelangelo ⁽¹⁾	Naturplus2 Matt	Rigata	288,55	288,55	288,55

Price are in €/m²

TOP LAYER	FEATURE	FINISH	GRADE	Module 1 total thickness 12,5 mm top layer thickness 3,5 mm dimensions 570x570 mm	Module 2 total thickness 12,5 mm top layer thickness 3,5 mm dimensions 190x1140 mm	Module 3 total thickness 12,5 mm top layer thickness 3,5 mm dimensions 380x1140 mm
OAK	Michelangelo ⁽¹⁾	Naturplus2 Matt ⁽²⁾	Elegant (Fibramix)	287,40	287,40	287,40
	Michelangelo ⁽¹⁾	Oleonature	Elegant (Fibramix)	294,35	294,35	294,35
	Fiesole 1125	Oleonature	Elegant (Fibramix)	294,35	294,35	294,35
	Civita 1695	Invisible Touch	Elegant (Fibramix)	310,85	310,85	310,85

Price are in €/m²

Waste due to elements' perimetric cutting is calculated between 5% and 10% though percentage may slightly vary according to dimension and shape of the surface area to be laid. Our technical departments is fully available to provide the correct quantity of required material.

Minimum quantity is 25 m². Smaller quantities are to be evaluated upon request. If accepted 300 € will be charged as setup **fixed costs**.

The delivered and invoiced quantity may exceed the one originally ordered with 4 m² or 4% tolerance (the highest between the two).

Before placing the order please check always availability and delivery time with the sales assistants.

⁽¹⁾ Available in Biancospino, Montblanc, Tortora colours.

⁽²⁾ The **Naturplus2** finish can be

ordered at no extra charge until 30/09/22. From this date on, it will be available as a customization: please ask the sales assistants for a quotation.

BISCUIT Nº1 | Design: Patricia Urquiola

The rounded cut softens the shape featuring a new and fascinating contemporary spirit to this wood floor that reinterprets the classic elegance of herringbone design. The slightly convex outline complements the design

whilst emphasizing the material sensations and the tactile experience of the wood. A project conceived by Patricia Urquiola boasting prestigious international design awards.





TOP LAYER THICKNESS: 3 / 3,5 mm

SUPPORT THICKNESS: 9 mm

TOTAL THICKNESS: 12,5 mm

SUPPORT: BIRCH MULTILAYER

WEIGHT: 9 kg/m²

THERMAL RESISTANCE: 0,077 m²K / W

INSTALLATION: GLUED-DOWN

12,5



| 3 / 3,5

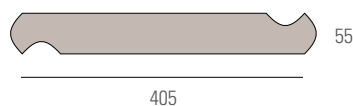
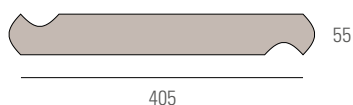

INSTALLATION PATTERN

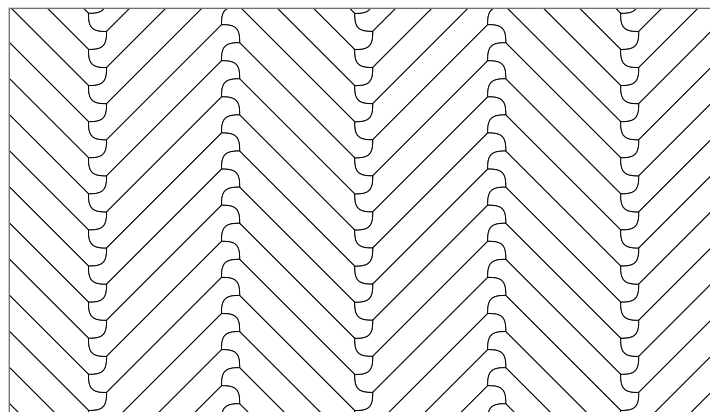

These products are compatible with heating and cooling underfloor systems provided they are installed with the glue down method and the instructions on operating temperature and humidity are strictly complied with.

We recommend to read the "General information" on page 4 and 5 during the selection and purchasing phase focusing on the installation, use and maintenance instructions available on www.listonegiordano.com.

Product's features may change with respect to the information in this document. For update information please check the technical sheets available on www.listonegiordano.com

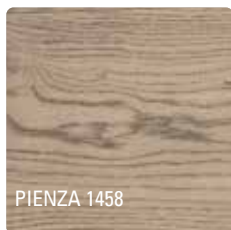
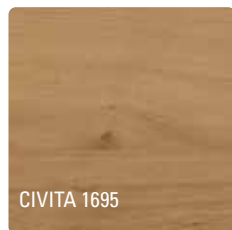

CIVITA 1695

PIENZA 1458

TOP LAYER	FEATURE	FINISH	GRADE	55 total thickness 12,5 mm top layer thickness 3 / 3,5 mm
OAK	Civita 1695	Invisible Touch	Elegant (Fibramix)	473,55
	Pienza 1458	Oleonature	Elegant (Fibramix)	479,25

Price are in €/m²

Minimum quantity is 12 m². Smaller quantities are to be evaluated upon request. If accepted 300 € will be charged as setup **fixed costs**. the sales assistants.

The delivered and invoiced quantity may exceed the one originally ordered with 4 m² or 4% tolerance (the highest between the two).

Before placing the order please always check availability and delivery time with



BISCUIT Nº2 | Design: Patricia Urquiola

The noble tradition of the double herringbone pattern comes back with a modern spirit, in a composition of decorative value.

The slightly convex outline complements the design emphasizing the material sensations and the tactile experience of the wood.



TOP LAYER THICKNESS: 3 / 3,5 mm

SUPPORT THICKNESS: 9 mm

TOTAL THICKNESS: 12,5 mm

SUPPORT: BIRCH MULTILAYER

WEIGHT: 9 kg/m²

THERMAL RESISTANCE: 0,077 m²K / W

INSTALLATION: GLUED-DOWN

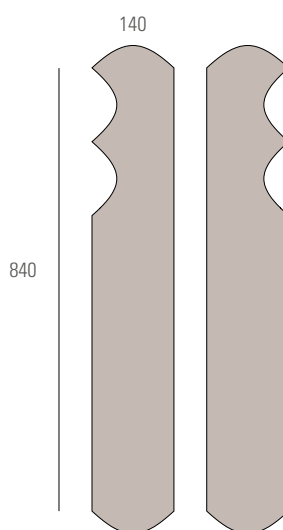
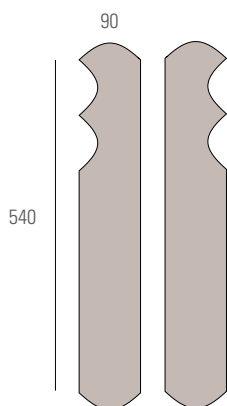
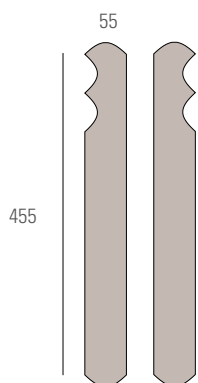

INSTALLATION PATTERNS

WIDTH 55

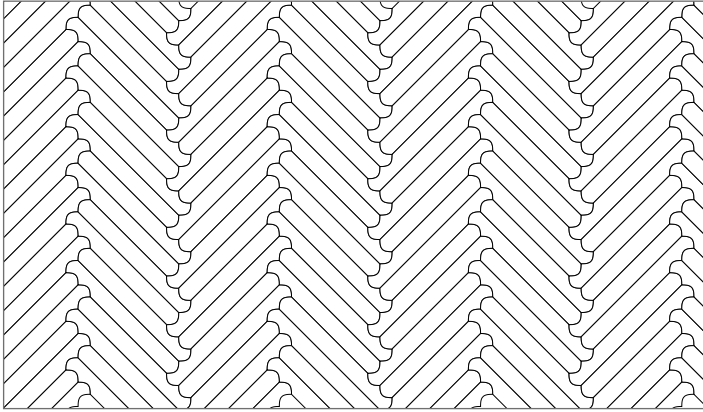

WIDTH 90

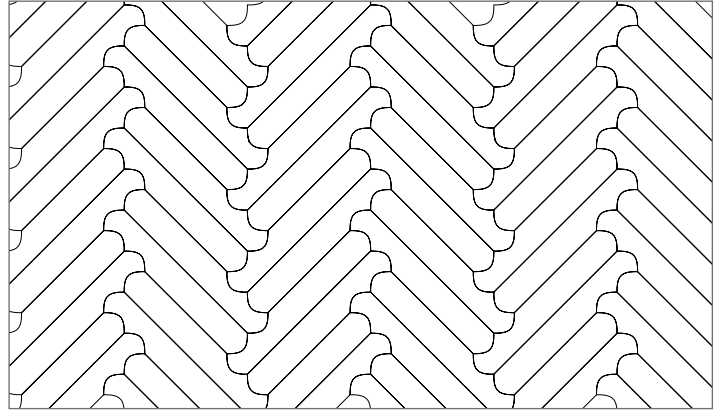

WIDTH 140

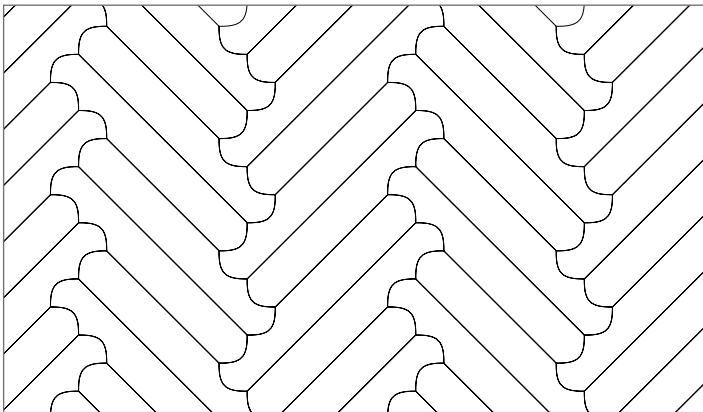

These products are compatible with heating and cooling underfloor systems provided they are installed with the glue down method and the instructions on operating temperature and humidity are strictly complied with.

We recommend to read the "General information" on page 4 and 5 during the selection and purchasing phase focusing on the installation, use and maintenance instructions available on www.listonegiordano.com.

Product's features may change with respect to the information in this document. For update information please check the technical sheets available on www.listonegiordano.com





TOP LAYER	FEATURE	FINISH	GRADE	140	90	55
				total thickness 12,5 mm top layer thickness 3 / 3,5 mm	total thickness 12,5 mm top layer thickness 3 / 3,5 mm	total thickness 12,5 mm top layer thickness 3 / 3,5 mm
OAK	Civita 1695	Invisible Touch	Elegant (Fibramix)	311,75	311,75	473,55
	Pienza 1458	Oleonature	Elegant (Fibramix)	317,45	317,45	479,25

Price are in €/m²

Minimum quantity is 12 m². Smaller quantities are to be evaluated upon request. If accepted 300 € will be charged as setup **fixed costs**.

the sales assistants.

The delivered and invoiced quantity may exceed the one originally ordered with 4 m² or 4% tolerance (the highest between the two).

Before placing the order please always check availability and delivery time with



A detailed composition of small pieces create a precious wood surface in which the decoration appears almost like chiseled refined bas-reliefs.

The slightly convex outline complements the design emphasizing the material sensations and the tactile experience of the wood.

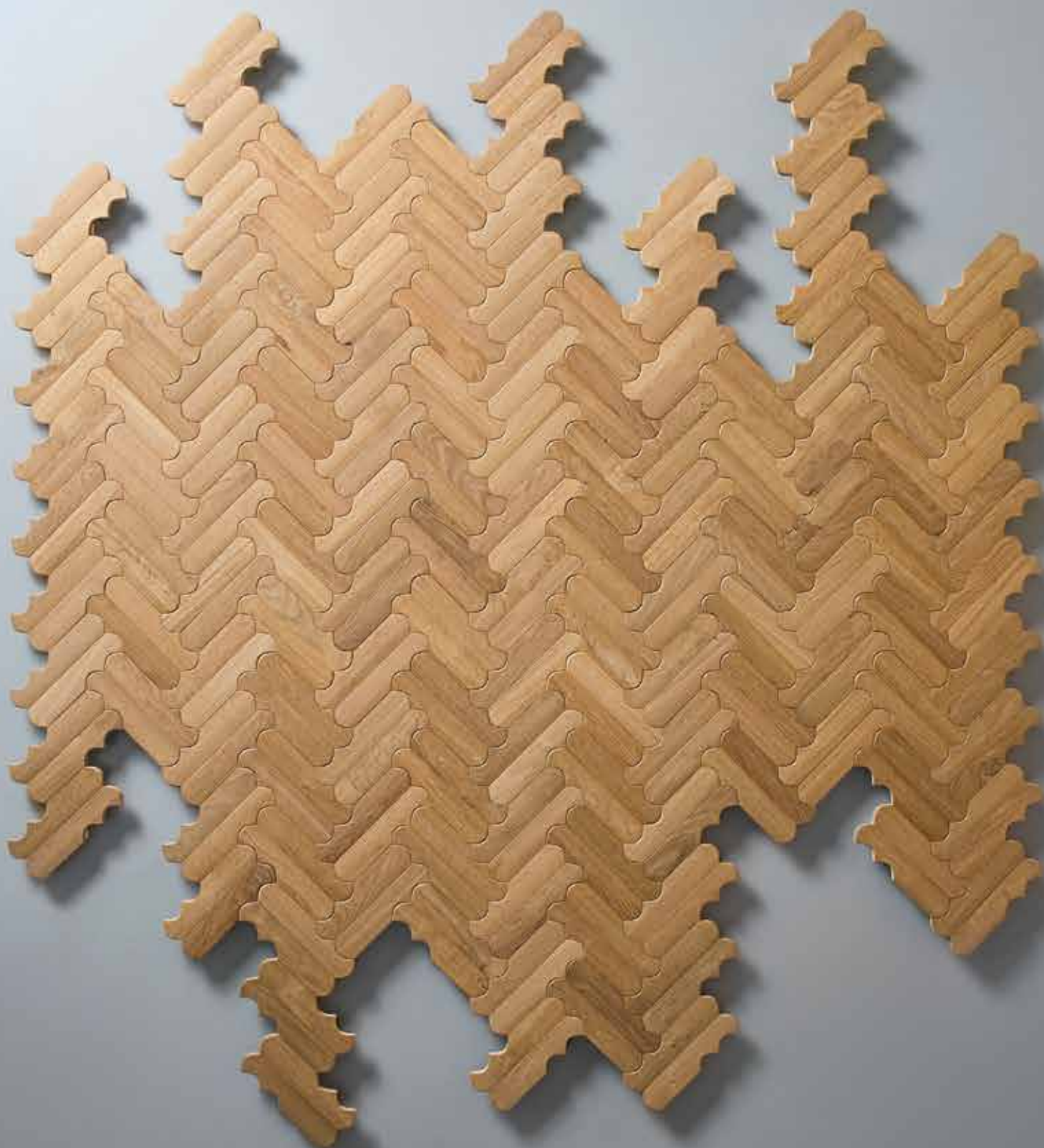



TOP LAYER THICKNESS: 3 / 3,5 mm

SUPPORT THICKNESS: 9 mm

TOTAL THICKNESS: 12,5 mm

SUPPORT: BIRCH MULTILAYER

WEIGHT: 9 kg/m²

THERMAL RESISTANCE: 0,077 m² K / W

INSTALLATION: GLUED-DOWN

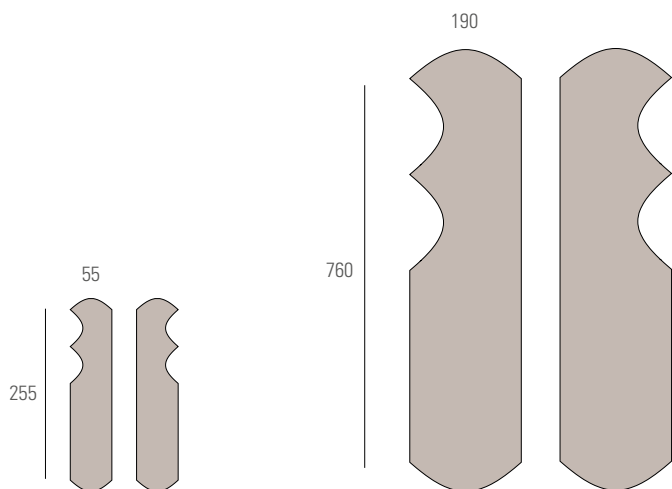

INSTALLATION PATTERNS

WIDTH 55

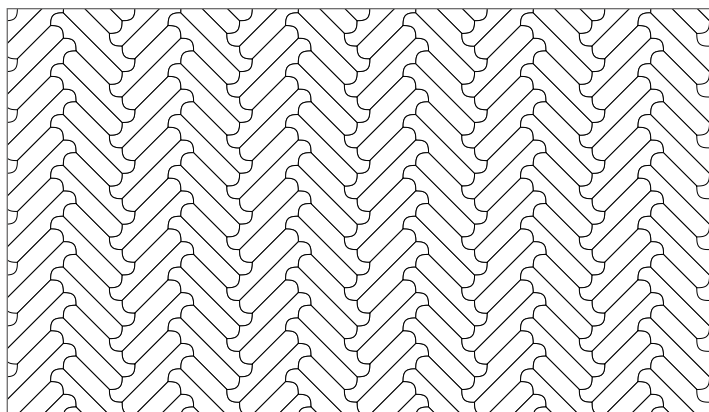

WIDTH 190

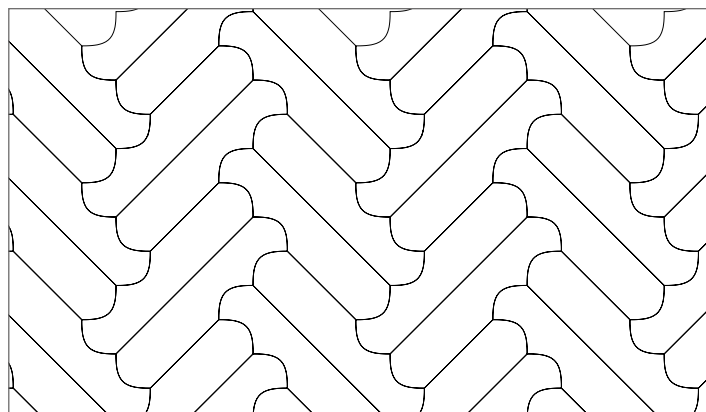

These products are compatible with heating and cooling underfloor systems provided they are installed with the glue down method and the instructions on operating temperature and humidity are strictly complied with.

We recommend to read the "General information" on page 4 and 5 during the selection and purchasing phase focusing on the installation, use and maintenance instructions available on www.listonegiordano.com.

Product's features may change with respect to the information in this document. For update information please check the technical sheets available on www.listonegiordano.com

BISCUIT N°3



TOP LAYER	FEATURE	FINISH	GRADE	190 total thickness 12,5 mm top layer thickness 3 / 3,5 mm	55 total thickness 12,5 mm top layer thickness 3 / 3,5 mm
OAK	Civita 1695	Invisible Touch	Elegant (Fibramix)	360,55	619,15
	Pienza 1458	Oleonature	Elegant (Fibramix)	366,25	624,80

Price are in €/m²

Minimum quantity is 12 m². Smaller quantities are to be evaluated upon request. If accepted 300 € will be charged as setup **fixed costs**. the sales assistants.

The delivered and invoiced quantity may exceed the one originally ordered with 4 m² or 4% tolerance (the highest between the two).

Before placing the order please always check availability and delivery time with



BISCUIT Nº5 SMALL | Design: Patricia Urquiola

It happens sometimes that wood boards “run” together side-by-side, having therefore to “smooth sharp edges” in order to rediscover an unprecedented harmony. Going so far as to “merge” and combine each other.

The slightly convex outline complements the design emphasizing the material sensations and the tactile experience of the wood.



TOP LAYER THICKNESS: 3 / 3,5 mm

SUPPORT THICKNESS: 9 mm

TOTAL THICKNESS: 12,5 mm

SUPPORT: BIRCH MULTILAYER

WEIGHT: 9 kg/m²

THERMAL RESISTANCE: 0,077 m²K / W

INSTALLATION: GLUED-DOWN



STANDARD ELEMENT

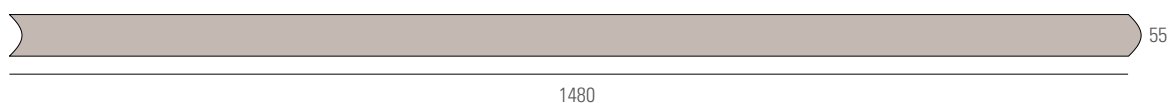

DECORATIVE ELEMENT

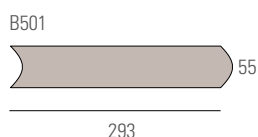

COLOUR INSERTS



INSTALLATION PATTERN

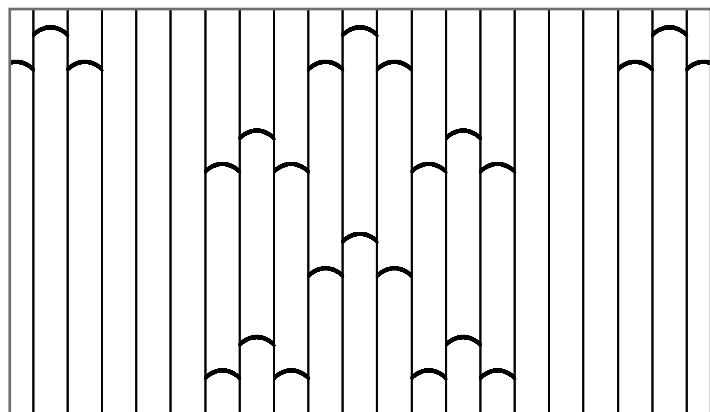

These products are compatible with heating and cooling underfloor systems provided they are installed with the glue down method and the instructions on operating temperature and humidity are strictly complied with.

We recommend to read the "General information" on page 4 and 5 during the selection and purchasing phase focusing on the installation, use and maintenance instructions available on www.listonegiordano.com.

Product's features may change with respect to the information in this document. For update information please check the technical sheets available on www.listonegiordano.com

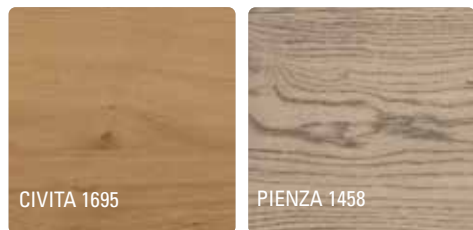

STANDARD ELEMENT

TOP LAYER	FEATURE	FINISH	GRADE	55 total thickness 12,5 mm top layer thickness 3 / 3,5 mm
OAK	Civita 1695	Invisible Touch	Elegant (Fibramix)	356,40
	Pienza 1458	Oleonature	Elegant (Fibramix)	362,10

Price are in €/m²

DECORATIVE ELEMENTS AND COLOUR INSERTS

FEATURE	DESCRIPTION	
B501	Oak from Fontaines decorative elements ⁽¹⁾	15,75
B511	Synthetic thermoplastic resin ABS (red code pantone 1805 U colour through all thickness)	1,00
B512	Synthetic thermoplastic resin ABS (green code pantone 334 U colour through all thickness)	1,00
B513	Synthetic thermoplastic resin ABS (white code Ral 9003 colour through all thickness)	1,00
B514	Synthetic thermoplastic resin ABS (blue code pantone 7469 U colour through all thickness)	1,00

Price are in €/pc

Minimum quantity is 12 m². Smaller quantities are to be evaluated upon request. If accepted 300 € will be charged as setup **fixed costs**.

The delivered and invoiced quantity may exceed the one originally ordered with 4 m² or 4% tolerance (the highest between the two).

Before placing the order please always check availability and delivery time with

the sales assistants.

⁽¹⁾ Please specify the product's version (Civita 1695 or Pienza1458) when placing the order of the matching decorative elements.

BISCUIT N°5 LARGE | Design: Patricia Urquiola

It happens sometimes that wood boards “run” together side-by-side, having therefore to “smooth sharp edges” in order to rediscover an unprecedented harmony. Going so far as to “merge” and combine each other.

The slightly convex outline complements the design emphasizing the material sensations and the tactile experience of the wood.





TOP LAYER THICKNESS: 3 / 3,5 mm

SUPPORT THICKNESS: 9 mm

TOTAL THICKNESS: 12,5 mm

SUPPORT: BIRCH MULTILAYER

WEIGHT: 9 kg/m²

THERMAL RESISTANCE: 0,077 m²K / W

INSTALLATION: GLUED-DOWN

12,5



3 / 3,5

STANDARD ELEMENTS

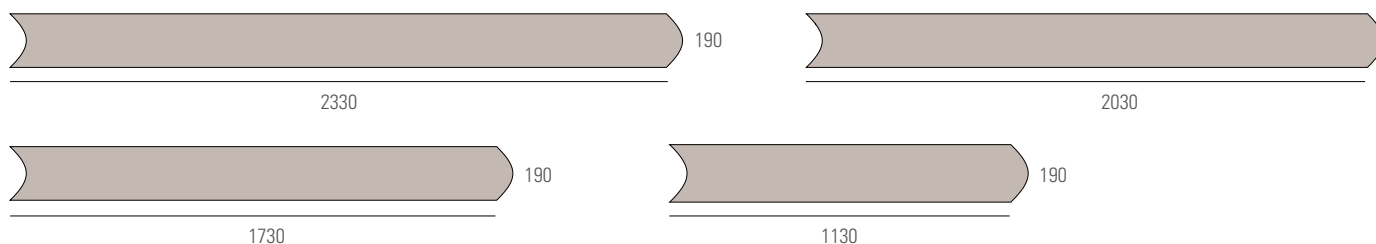

DECORATIVE ELEMENTS

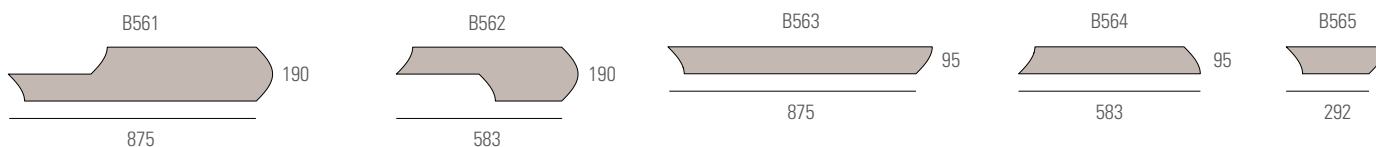

INSTALLATION PATTERN

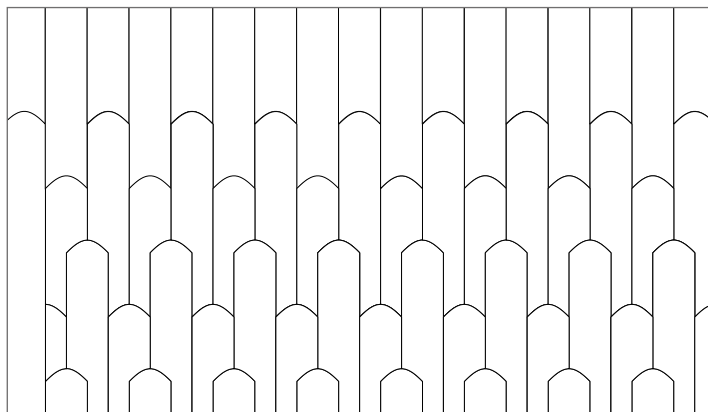

COLOUR INSERTS

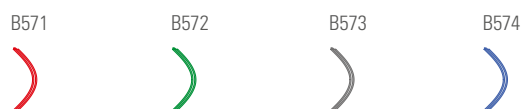

These products are compatible with heating and cooling underfloor systems provided they are installed with the glue down method and the instructions on operating temperature and humidity are strictly complied with.

We recommend to read the "General information" on page 4 and 5 during the selection and purchasing phase focusing on the installation, use and maintenance instructions available on www.listonegiordano.com.

Product's features may change with respect to the information in this document. For update information please check the technical sheets available on www.listonegiordano.com

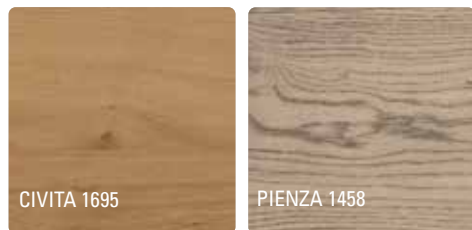

STANDARD ELEMENT

TOP LAYER	FEATURE	FINISH	GRADE	190 total thickness 12,5 mm top layer thickness 3 / 3,5 mm
OAK FROM FONTAINES	Civita 1695	Invisible Touch	Elegant (Fibramix)	314,25
	Pienza 1458	Oleonature	Elegant (Fibramix)	319,95

Prices are in €/m²

DECORATIVE ELEMENTS AND COLOUR INSERTS

FEATURE	DESCRIPTION	
B561	Oak from Fontaines decorative elements ⁽¹⁾	88,60
B562	Oak from Fontaines decorative elements ⁽¹⁾	65,85
B563	Oak from Fontaines decorative elements ⁽¹⁾	86,25
B564	Oak from Fontaines decorative elements ⁽¹⁾	63,25
B565	Oak from Fontaines decorative elements ⁽¹⁾	44,30
B571	Synthetic thermoplastic resin ABS (red code pantone 1805 U colour through all thickness)	1,30
B572	Synthetic thermoplastic resin ABS (green code pantone 334 U colour through all thickness)	1,30
B573	Synthetic thermoplastic resin ABS (white code Ral 9003 colour through all thickness)	1,30
B574	Synthetic thermoplastic resin ABS (blue code pantone 7469 U colour through all thickness)	1,30

Prices are in €/pc

Minimum quantity is 12 m². Smaller quantities are to be evaluated upon request. If accepted 300 € will be charged as setup **fixed costs**.

The delivered and invoiced quantity may exceed the one originally ordered with 4 m² or 4% tolerance (the highest between the two).

Before placing the order please always check availability and delivery time with

the sales assistants.

⁽¹⁾ Please specify the product's version (Civita 1695 or Pienza1458) when placing the order of the matching decorative elements.

The precious birch top layer acquires the rich textile's new personality thanks to the innovative surface treatment, colors and crossed-burshed technique. Fabrique has its own story to tell, evoking the great industrial revolutions

when technology moved at high-speed creating new lifestyles. And man has flown up with it tracking his roots down. It's the reality we face today.





TOP LAYER THICKNESS: 3,5 mm
 SUPPORT THICKNESS: 9 mm
 TOTAL THICKNESS: 12,5 mm
 SUPPORT: BIRCH MULTILAYER
 WEIGHT: 9 kg/m²
 THERMAL RESISTANCE: 0,078 m² K / W
 INSTALLATION: GLUED-DOWN

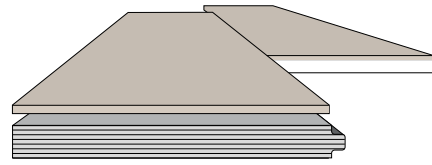

INSTALLATION PATTERNS

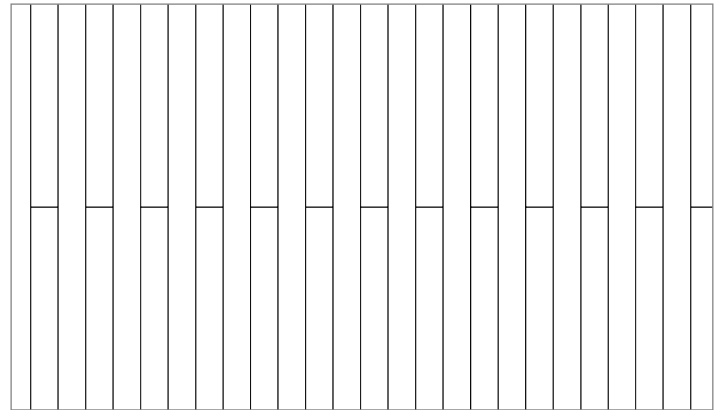

These products are compatible with heating and cooling underfloor systems provided they are installed with the glue down method and the instructions on operating temperature and humidity are strictly complied with.

Product's features may change with respect to the information in this document.
 For update information please check the technical sheets available on

www.listonegiordano.com.

We recommend to read the "General information" on page 4 and 5 during the selection and purchasing phase focusing on the installation, use and maintenance instructions available on www.listonegiordano.com.

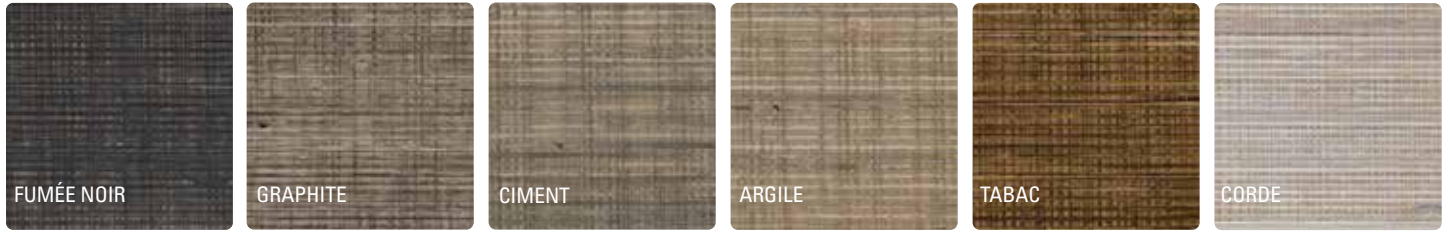

TOP LAYER	FEATURE	FINISH	90 total thickness 12,5 mm top layer thickness 3,5 mm length 1200 mm
BIRCH PLYWOOD	Fumée Noire	Oleonature	233,25
	Graphite	Oleonature	233,25
	Ciment	Oleonature	233,25
	Argile	Oleonature	233,25
	Tabac	Oleonature	233,25
	Corde	Oleonature	233,25

Price are in €/m²

The product's width may range from 80 to 90 mm according to availability.

Products are produced in **one length**. The supply may include up to 10% of the total surface shorter lengths compared to the one above mentioned.

The surface may show filled or partially open gaps as well as light mottled color variegation and non homogenous hue. These are typical characteristics of the product.

Minimum quantity is 25 m². Smaller quantities are to be evaluated upon request. If accepted 300 € will be charged as setup **fixed costs**.

The delivered and invoiced quantity may exceed the one originally ordered with 4 m² or 4% tolerance (the highest between the two).

Before placing the order please check always availability and delivery time

with the sales assistants.



perigal

| In cooperation with: Paola Lenti

Perigal is an original wooden floor inspired by the celebrated, dissection-based proof of the Pythagorean theorem and its brilliant geometry. An unusual union of knowledge provides new lifeblood – it is in fact the outstanding

result of the encounter between Listone Giordano's wealth of wood expertise and Paola Lenti's unmistakable, signature style.





Perigal | Linden Graphite

*Elementi Fuorisalone 2018 - Paola Lenti
Ph. by Sergio Chimenti*

TOP LAYER THICKNESS: 1 mm
 SUPPORT THICKNESS: 12 mm
 TOTAL THICKNESS: 13 mm
 SUPPORT: MULTILAYER COUNTER-BALANCED
 WEIGHT: 9 kg/m
 THERMAL RESISTANCE: 0,074 m² K / W
 INSTALLATION: GLUED-DOWN

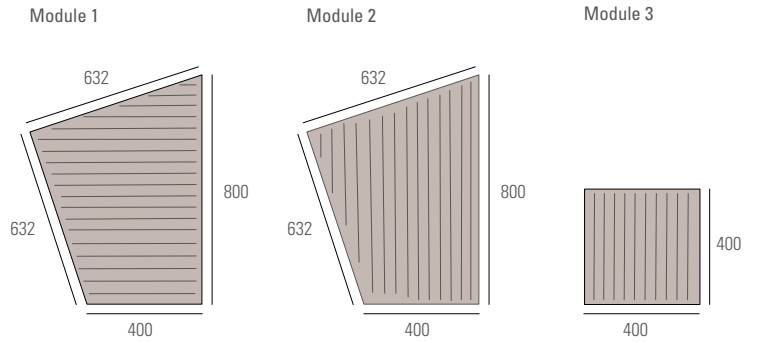
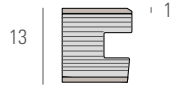

INSTALLATION PATTERNS

N.1

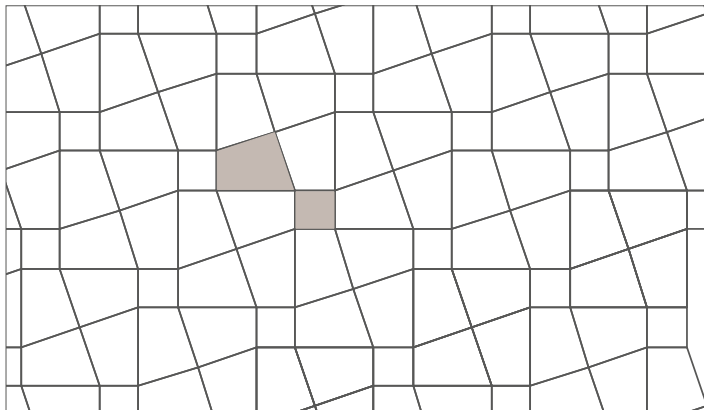

N.2

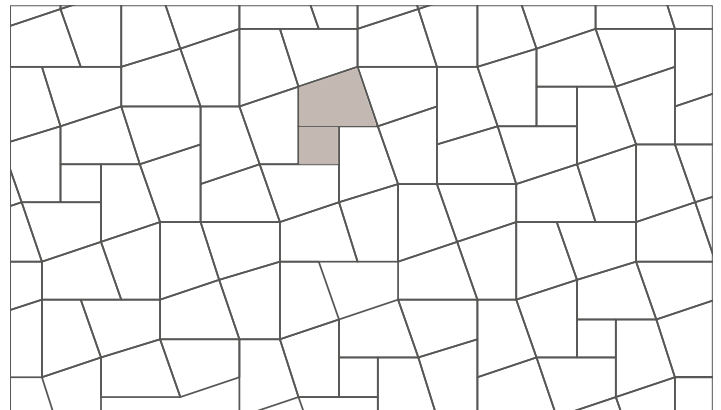

N.3

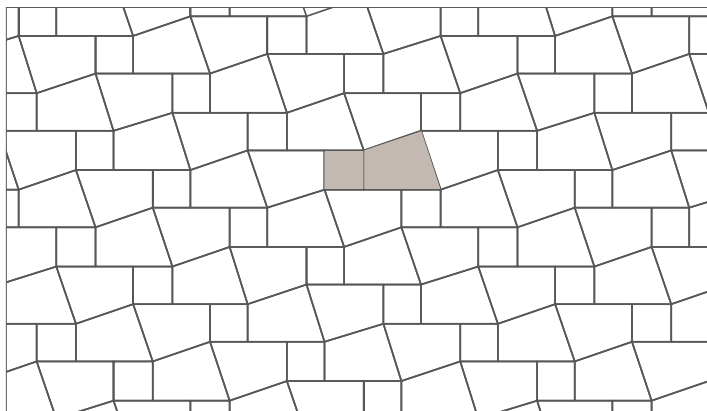

N.4

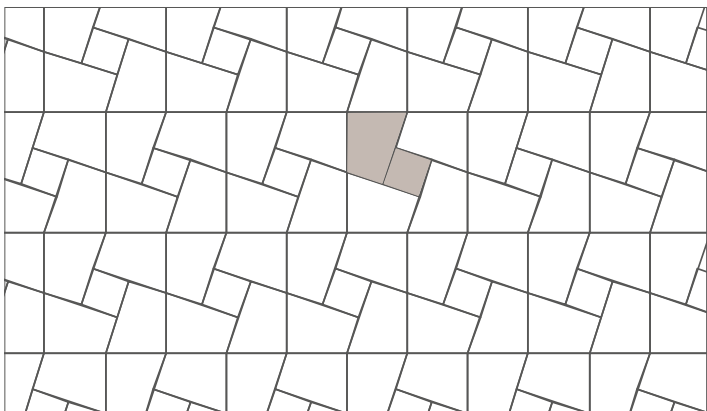

N.5

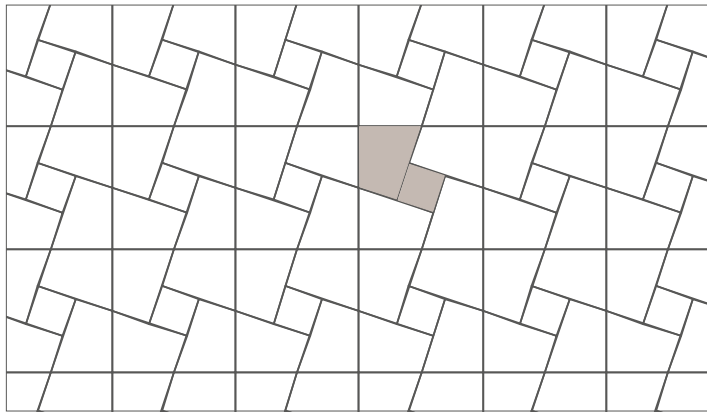

N.6

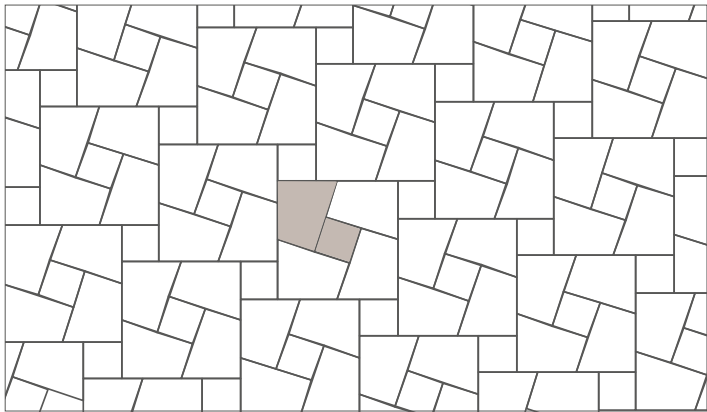

N.7

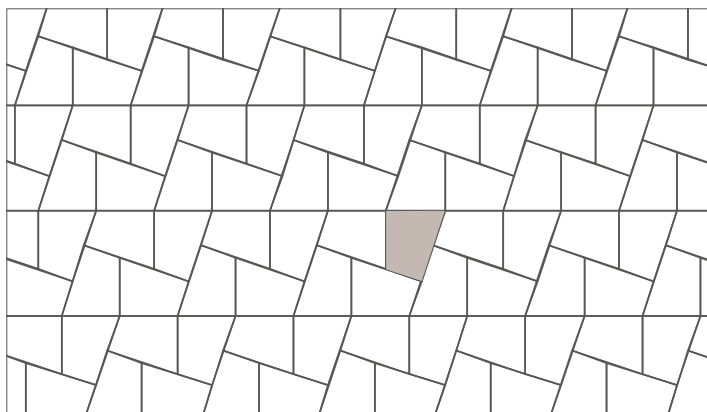

N.8

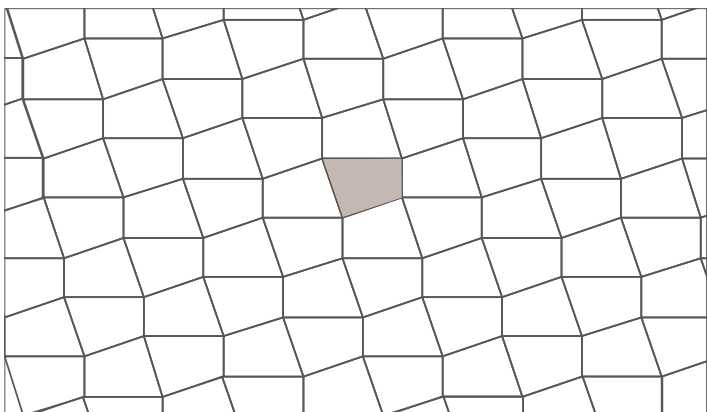

These elements are milled with groove profiles on four sides. They interlock by means of split tongues supplied with the material.

Please check the technical sheets for more information on the installation patterns.

These products are compatible with heating and cooling underfloor systems provided they are installed with the glue

down method and the instructions on operating temperature and humidity are strictly complied with.

Product's features may change with respect to the information in this document. For update information please check the technical sheets available on www.listonegiordano.com

We recommend to read the "General information" on page 4 and 5 during

the selection and purchasing phase focusing on the installation, use and maintenance instructions available on www.listonegiordano.com.





TOP LAYER	FEATURE	FINISH	GRADE	total thickness 13 mm top layer thickness 1 mm
LINDEN	Graphite	Oleonature	Elegant (Fibramix)	362,40
	Ottanio	Oleonature	Elegant (Fibramix)	382,70
	Acqua	Oleonature	Elegant (Fibramix)	382,70
	Olio	Oleonature	Elegant (Fibramix)	382,70

Price are in €/m²

A preliminary project of the surface is necessary to order the correct number of Modules and related waste due to perimeter cutting of the elements, usually calculated between 10% and 20% though percentage may slightly vary according to dimension and shape of the surface area to be laid.

Our technical department is available, on the basis of CAD drawings provided by the client, to elaborate the floor plan drawings and detailed list of the

number of modules required for flooring installation.

Minimum quantity is 25 m². Smaller quantities are to be evaluated upon request. If accepted 300 € will be charged as setup **fixed costs**.

The delivered and invoiced quantity may exceed the one originally ordered with 4 m² or 4% tolerance (the highest between the two).

Before placing the order please check always availability and delivery time with the sales assistants.



Perigal | Linden Graphite

*Elementi Fuorisalone 2018 - Paola Lenti
Ph. by Sergio Chimenti*

In the flooring project Between, matter takes shape in a precious and at the same time light texture, becoming a key interpretation. for interior solutions. The brass elements seem to find new warmth in the heritage of knowledge and a centuries-old passion for wood. A flooring application which has

managed to combine innovation and craftsmanship over time, in search of a contemporary language and original and refined forms of expression.





TOP LAYER THICKNESS: 3,5 mm
 SUPPORT THICKNESS: 9 mm
 TOTAL THICKNESS: 12,5 mm
 SUPPORT: BIRCH MULTILAYER
 WEIGHT: 9 kg/m²
 THERMAL RESISTANCE: 0,077 m² K/W
 INSTALLATION: GLUED-DOWN

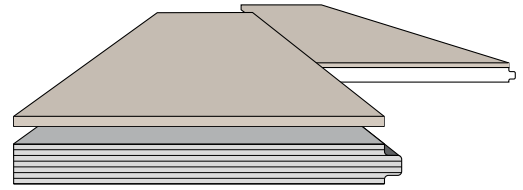

INSERT

brass insert



INSTALLATION PATTERN

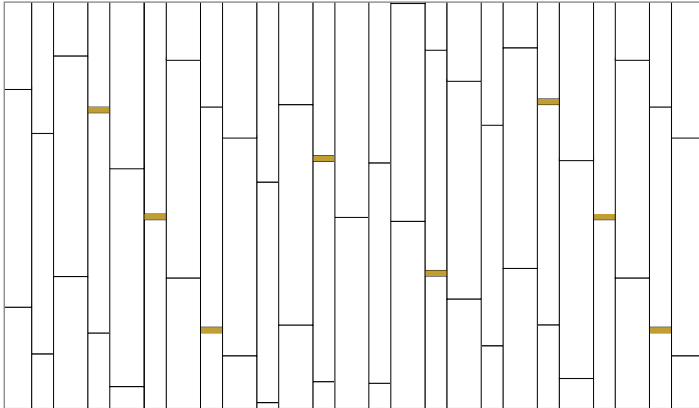

The modules feature tongue and groove profile on four sides.

These products are compatible with heating and cooling underfloor systems provided they are installed with the glue down method and the instructions on operating temperature and humidity are strictly complied with.

Product's features may change with respect to the information in this

document. For update information please check the technical sheets available on www.listonegiordano.com

We recommend to read the "General information" on page 4 and 5 during the selection and purchasing phase focusing on the installation, use and maintenance instructions available on www.listonegiordano.com.



TOP LAYER	FEATURE	SURFACE	FINISH	GRADE	90 - 140 total thickness 12,5 mm top layer thickness 3,5 mm length 1190 mm
OAK	Monteriggioni 1213 <i>brass insert (1 pc/m²)</i>	filigrana	Invisible Touch	Elegant (Fibramix)	305,60

Price are in €/m²

Products are produced in **one length**. The supply may include up to 10% of the total surface shorter lengths compared to the one above mentioned.

Minimum quantity is 25 m². Smaller quantities are to be evaluated upon request. If accepted 300 € will be charged as setup **fixed costs**.

The delivered and invoiced quantity may exceed the one originally ordered with 4 m² or 4% tolerance (the highest

between the two).

Before placing the order please check always availability and delivery time with the sales assistants.



A "lateral thought" or rather an inverted thought was the compass that guided the German architect to rediscover proportions - inspired by the ancient Roman model - in the full and respectful use of a precious material. The square and rectangular shapes and the wood grain change and alternate

creating an unoriented floor, which follows free and fluid spatial sequences. A balance of relationships and proportions make up a wooden floor that knows how to amaze and surprise in the name of simplicity and logic of timeless beauty.





TOP LAYER THICKNESS: 3,5 mm
 SUPPORT THICKNESS: 9 mm
 TOTAL THICKNESS: 12,5 mm
 SUPPORT: BIRCH MULTILAYER
 WEIGHT: 9 kg/m²
 THERMAL RESISTANCE: 0,077 m² K/W
 INSTALLATION: GLUED-DOWN

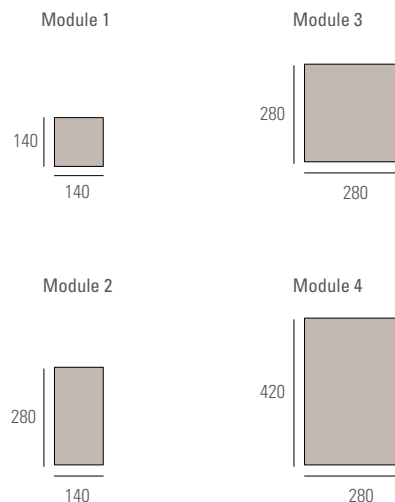
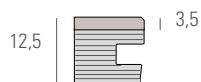

INSTALLATION PATTERN



Elements are milled with tongue and groove profiles on the long sides and groove profile on both short sides. They interlock by means of split tongues supplied with the material.

Each packaging unit contains 4 elements "Module 1", 2 elements "Module 2", 4 elements "Module 3" and 2 elements of "Module 4".

These products are compatible with

heating and cooling underfloor systems provided they are installed with the glue down method and the instructions on operating temperature and humidity are strictly complied with.

Product's features may change with respect to the information in this document. For update information please check the technical sheets available on www.listonegiordano.com

We recommend to read the "General information" on page 4 and 5 during the selection and purchasing phase focusing on the installation, use and maintenance instructions available on www.listonegiordano.com.

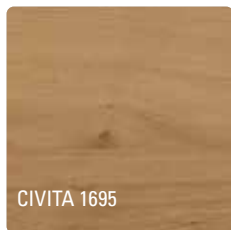

TOP LAYER	FEATURE	SURFACE	FINISH	GRADE	total thickness 12,5 mm top layer thickness 3,5 mm
OAK	Civita 1695	filigrana	Invisible Touch	Elegant (Fibramix)	442,25

Price are in €/m²

Minimum quantity is 25 m². Smaller quantities are to be evaluated upon request. If accepted 300 € will be charged as setup **fixed costs**.

The delivered and invoiced quantity may exceed the one originally ordered with 4 m² or 4% tolerance (the highest between the two).

Before placing the order please check always availability and delivery time with the sales assistants.



loop

| Design: Sebastiano Canzano

Can a geometric shape play hide and seek with our perceptions and endlessly push forward the borderline, the concept of limit? Loop is a wooden furniture

surface that amazes for its ability to seamlessly embrace the space with amusing naturalness.





TOP LAYER THICKNESS: 2,5 mm
 SUPPORT THICKNESS: 9 mm
 TOTAL THICKNESS: 11,5 mm
 SUPPORT: BIRCH MULTILAYER
 WEIGHT: 7,5 kg/m²
 THERMAL RESISTANCE: 0,092 m² K/W
 INSTALLATION: GLUED-DOWN

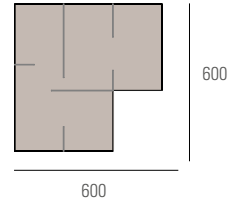

INSTALLATION PATTERN

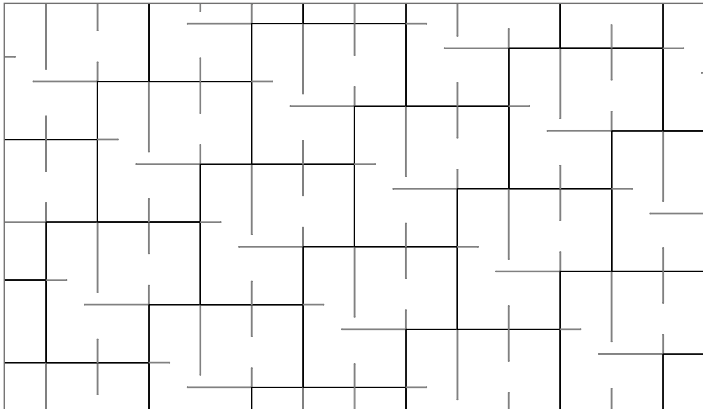

Elements are milled with tongue and groove profiles.

These products are compatible with heating and cooling underfloor systems provided they are installed with the glue down method and the instructions on operating temperature and humidity are strictly complied with.

Product's features may change with respect to the information in this

document. For update information please check the technical sheets available on www.listonegiordano.com.

We recommend to read the "General information" on page 4 and 5 during the selection and purchasing phase focusing on the installation, use and maintenance instructions available on www.listonegiordano.com.



TOP LAYER	FEATURE	FINISH	GRADE	
AYOUS	Greige	Oleonature	Rigata	total thickness 11,5 mm top layer thickness 2,5 mm dimensions 600x600 mm
				350,75

Price are in €/m²

Waste due to elements' perimetric cutting is calculated between 10% and 15% though percentage may slightly vary according to dimension and shape of the surface area to be laid.

Our technical departments is fully available to provide the correct quantity of required material.

Minimum quantity is 25 m². Smaller quantities are to be evaluated upon

request. If accepted 300 € will be charged as setup **fixed costs**.

The delivered and invoiced quantity may exceed the one originally ordered with 4 m² or 4% tolerance (the highest between the two).

Before placing the order please check always availability and delivery time with the sales assistants.



factum

Design: Dante Oscar Benini and Luca Gonzo

The artistic thoughts of great masters are interpreted in a contemporary square element that offers a distillate of pure Italian style. Wood surfaces with endless compositions and rhythms give life to carpets or elegant

tapestries with a strong visual impact. Factum expresses the need for aesthetic spirituality and inner research.





TOP LAYER THICKNESS: 1 mm
 SUPPORT THICKNESS: 12 mm
 TOTAL THICKNESS: 13 mm
 SUPPORT: MULTILAYER COUNTER-BALANCED
 WEIGHT: 9 kg/m
 THERMAL RESISTANCE: 0,083 m² K / W
 INSTALLATION: GLUED-DOWN

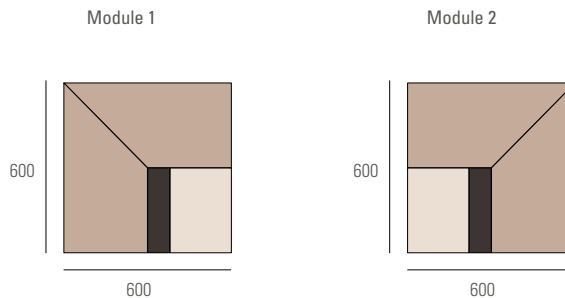
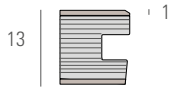

INSTALLATION PATTERNS

N.1

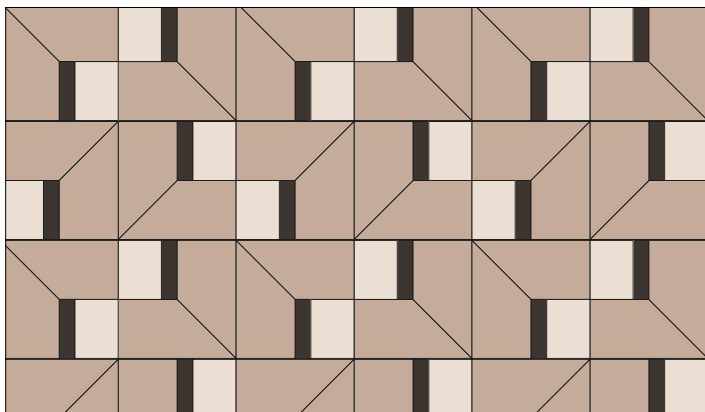

N.2

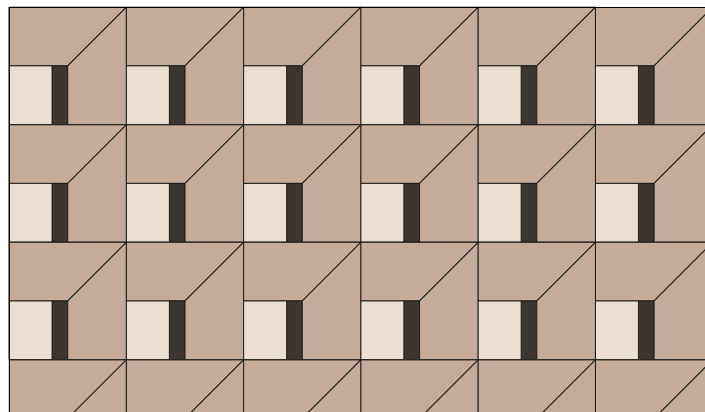

N.3

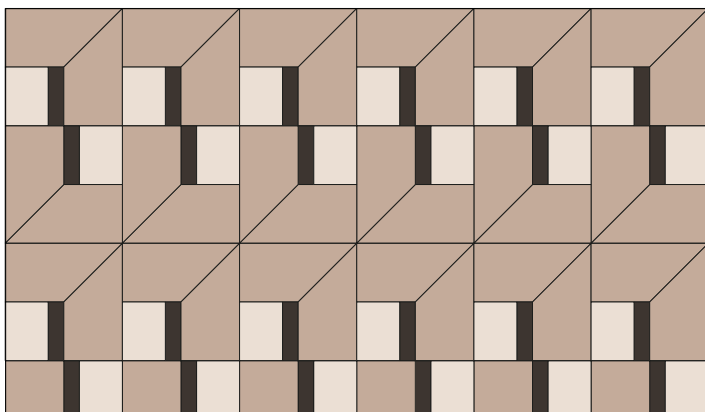

N.4

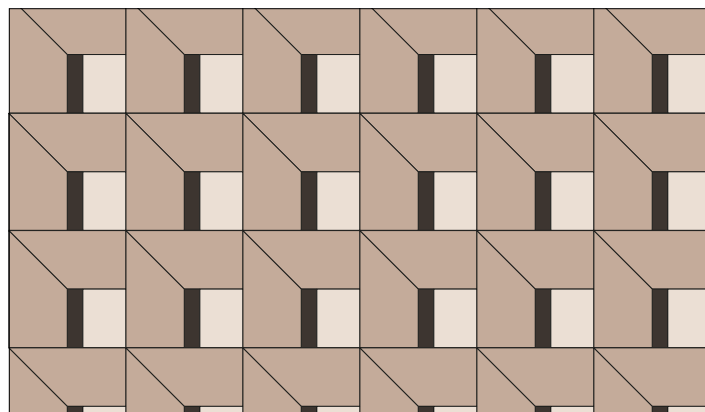

These elements are milled with groove profiles on four sides. They interlock by means of split tongues supplied with the material.

Please check the technical sheets for more information on the installation patterns.

These products are compatible with heating and cooling underfloor systems

provided they are installed with the glue down method and the instructions on operating temperature and humidity are strictly complied with.

Product's features may change with respect to the information in this document. For update information please check the technical sheets available on www.listonegiordano.com.

We recommend to read the "General information" on page 4 and 5 during the selection and purchasing phase focusing on the installation, use and maintenance instructions available on www.listonegiordano.com.



TOP LAYER	FEATURE	FINISH	GRADE	total thickness 13 mm top layer thickness 1 mm
OAK	Tabby ⁽¹⁾	Naturplus2 Matt	Rigata	453,00

Price are in €/m²

Waste due to elements' perimetric cutting is calculated between 5% and 10% though percentage may slightly vary according to dimension and shape of the surface area to be laid.

Our technical departments is fully available to provide the correct quantity of required material.

Minimum quantity is 25 m². Smaller

quantities are to be evaluated upon request. If accepted 300 € will be charged as setup **fixed costs**.

The delivered and invoiced quantity may exceed the one originally ordered with 4 m² or 4% tolerance (the highest between the two).

Before placing the order please check always availability and delivery time with the sales assistants.

⁽¹⁾ Each module is made with colors Grigio Dolomite, Grigio di Marna and Grigio Porfido.



ACCESSORIES

STAIR NOSINGS (TYPE A) (1) (2)

	l	a	b	PRODUCTS		
	length	width	frontal height			
	1200 mm	190 mm	40 mm	MEDOC	Oak	177,90

Prices are in €/pc

STAIR NOSINGS (TYPE B) (2)

	l	a	b	PRODUCTS		
	length	width	frontal height			
	1200 mm	190 mm	190 mm	MEDOC	Oak	232,40

Prices are in €/pc

REDUCERS (2)

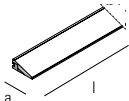
	l	a	PRODUCTS		
	length	width			
	30 mm	1200 mm	MEDOC	Oak	68,00

Prices are in €/pc

When placing the order, please specify the characteristics of the corresponding wood floor.

These products are manufactured upon request. The delivery time for standard elements is approx 30 days from order confirmation. For products with

dimensions, shapes and colours other than the standard ones, prices and delivery time are to be confirmed each individual time.

The standard elements of stair nosings are not designed to be fitted side-by-side. If you require this kind of

installation please check feasibility, costs and timing with the sales assistants.

These products have the typical tolerances of a handcraft processing. The Slide, Foxtrot, Biscuit, Fabrique, Perigal, Between, Conte, Factum, Loop

collections do not feature standard accessory elements (reducers, stair nosings) as they are normally part of an integrated interior design solution. Customized accessory elements may be produced, quotation upon request.

LINGOTTO LISTONE GIORDANO

PRODUCTS		
	Aluminum "Listone Giordano" brand plate including a wooden board with built-in plate	69,00

Prices are in €/pc

ADHESIVE

PRODUCTS		
	ECOLFIT (environmentally-friendly one-component silane adhesive) - 14 kg tin Average yield: 1,2 Kg/m ² . It is strictly connected to the conditions of the subfloor.	7,95 €/Kg

⁽¹⁾ The front of Stair nosing "type A" does not feature any surface treatment.

⁽²⁾ Independently from the type of installation of the corresponding wood floor, stair nosings and reducers are to be used glued-down

WHITE SKIRTING BOARD

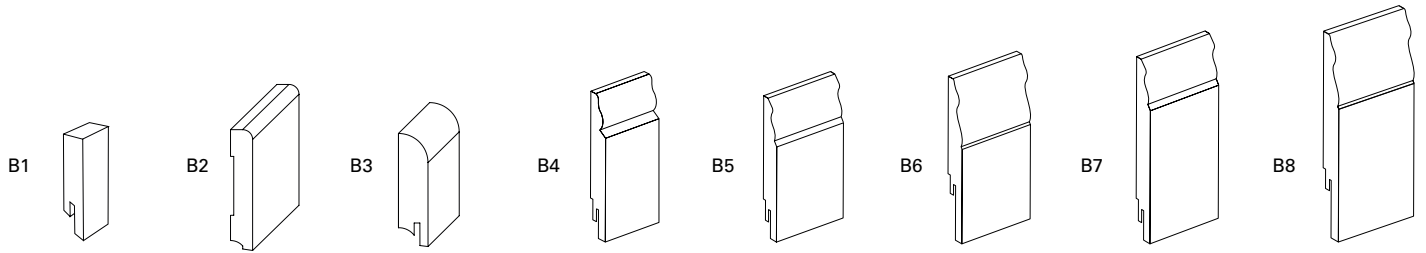

Profile	Height	Thickness	Length	Pre-treated ⁽¹⁾	White RAL 9003	White RAL 9010
B1	45 mm	13 mm	2,40 m	-	4,80	4,80
B1	50 mm	10 mm	2,40 m	-	4,80	4,80
B2	80 mm	14 mm	2,40 m	6,60	-	-
B3	60 mm	16 mm	2,40 m	-	7,30	7,30
B3	70 mm	10 mm	2,40 m	-	4,00	4,00
B4	96 mm	16 mm	2,40 m	-	8,60	8,60
B5	96 mm	16 mm	2,40 m	-	8,60	8,60
B6	108 mm	16 mm	2,40 m	-	8,80	8,80
B7	118 mm	16 mm	2,40 m	-	9,00	9,00
B8	130 mm	16 mm	2,40 m	-	9,60	9,60

Price are in €/m

⁽¹⁾ Untreated product to be finished on site with color of choice.

WOODEN SKIRTING BOARD

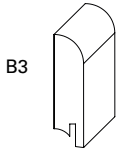

Profile	Heigh	Thickness	Length	Woods	Invisible Touch	Oleonature	Naturplus2
B1	50 mm	10 mm	2,40 m	Oak Biancospino, Montblanc, Tortora	-	9,90	9,90
B1	50 mm	10 mm	2,40 m	Oak Cannella, Grigio di Luna	-	-	10,80
B3	70 mm	10 mm	2,40 m	Oak Civita	9,90	-	-
B3	70 mm	10 mm	2,40 m	Oak Pienza, San Gimignano, Montalcino, Bagno Vignoni, Erice	-	10,80	-
B3	70 mm	10 mm	2,40 m	Oak Grigio Dolomite, Grigio di Marna, Grigio Porfido	-	-	10,80
B3	70 mm	10 mm	2,40 m	Oak Fiesole	-	9,90	-
B3	60 mm	16 mm	2,40 m	Oak Erice	-	15,90 ⁽¹⁾	-

Price are in €/m

The skirting boards do not feature any surface treatments, except for Oak Erice 60x16 mm.

The wood veneer coating of the skirting board (veneered version) may show different grain and colour tone compared to the related wood flooring material.

It is recommended to use white skirting boards to match Fabrique, Perigal, Medoc Mirantico, Between and Loop floors.

⁽¹⁾ Supplied in version with cut-sawn effect.



CLEANING AND MAINTENANCE PRODUCTS

	Product yield	€/package
HOUSEHOLD USE		
green Mild detergent, based on surfactants of vegetable origin (obtained from beet, coconut oil, wheat) and completely biodegradable (according to 648/2004 CE regulation), for the cleaning of wooden floors with Naturplus2, Naturplus2 Matt, Invisible Touch and Oleonature finishes.	800 m ² / package	9,95
vitanova Aqueous emulsion product for protecting wooden floors with Invisible Touch finish. It allows to renew as well the Crystalcare antibacterial protection.	30 m ² / package	39,55
revivo Natural oil-wax, water-based solution, for conditioning and protecting wooden floors with Oleonature finish. It allows to renew as well the Crystalcare antibacterial protection.	30 m ² / package	27,85
PROFESSIONAL USE		
plusnovo Product designed to reduce the whitish effect of scratches on the surface of Naturplus2 finished wood floors. Available in various colours.	- (1)	20,00 lt. 0,25
plusnovo matt Product designed to reduce the whitish effect of scratches on the surface of Naturplus2 matt finished wood floors. Available in various colours.	- (1)	20,00 lt. 0,25
ITnovo Specific product to regenerate scratches and small stains on Invisible Touch finished wood floors.	- (1)	20,00 lt. 0,25
renovo Specific product to regenerate scratches and minor stains of Oleonature finished wood floors. Available in various colours.	- (1)	20,00 lt. 0,25
puliplus Detergent for removing glue residues and stubborn stains from the surface of varnished wooden floors.	- (1)	14,50
extraclean Strong detergent to remove stubborn dirt from varnished wooden floors.	40 m ² / package	11,60
revivo pro Natural oil-wax, water-based solution, for extraordinary maintenance of wooden floors with Oleonature finish. It allows to renew as well the Crystalcare antibacterial protection.	30 m ² / package	36,50

Unless otherwise specified the products are supplied in 1-litre bottles.

⁽¹⁾ These products' yield cannot be quantified according to the m² of the floor.

Please check the technical sheets available on www.listonegiordano.com for information on using the products.

COMPATIBILITY CHART

FINISH	DOMESTIC USE		PROFESSIONAL USE	
	CLEANING	ORDINARY MAINTENANCE	CLEANING AND MAINTENANCE EXTRAORDINARY	RESTORATION
NATURPLUS2 MATT			PULIPLUS EXTRACLEAN	PLUSNOVO MATT
INVISIBLE TOUCH		VITANOVA	PULIPLUS EXTRACLEAN	ITNOVO
OLEONATURE		REVIVO	REVIVO PRO	RENOVO